

Electronics I. laboratory measurement guide

4. Measurement

Basic circuits with operational amplifiers

2022.11.16.

In this measurement you will need both controllable voltage outputs of the power supply, take care to connect them in the correct polarity! **Setup about 20mA current limit on both.**

We are using the LM741 or compatible operation amplifier integrated circuit, but the LM258 or compatible can also appear (based on shop availability). Most 8 pin DIP package opamps are pin-compatible with one of these. Therefore, before starting the measurement, check which opamp you have and look up its pinout on the billboard in the laboratory. We suggest writing the pin numbers onto your circuit diagram before starting measurement.

Note: For the LM258/358 opamp a resistor (R3) is needed between the output and the negative power supply (to improve the quality of the output signal). This resistor is not part of the circuits studied in theory. For the 741, this resistor is not required.

4.1 Inverting amplifier

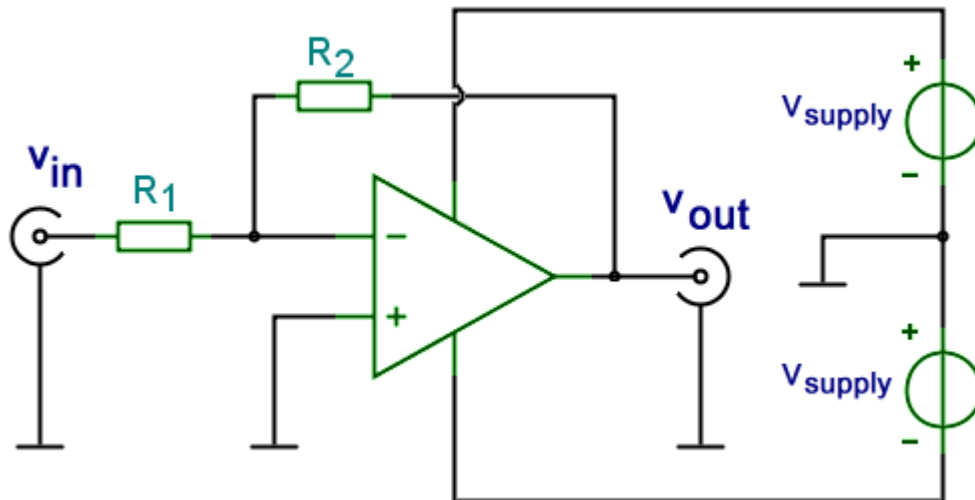

Figure 4.1 Inverting amplifier circuit

Build the circuit seen on figure 4.1. Take care of the correct polarity of the double power supply! Parameters: $R_1=1\text{k}\Omega$; $R_2=10\text{k}\Omega$; $V_{\text{supply}}=10\text{V}$.

4.1.1 First, connect V_{in} to the ground (zero potential) instead of the function generator. In this case both inputs are at 0V therefore the output should be $V_{\text{out}}=0$. Measure the actual output voltage using the multimeter in DC mV setting. (This will be the output offset voltage.)

4.1.2 Disconnect V_{in} from the ground and connect it to the analog output of the function generator. Also connect that point to the oscilloscope channel 1 (it is suggested to use the T-junction and BNC-BNC cables). Connect V_{out} to the channel 2 of the oscilloscope.

4.1.3 Setup 1kHz, 1Vpp (peak to peak) sine wave on the function generator. Draw and measure the input and output waveforms (peak to peak voltage, phase, voltage gain). Calculate the voltage gain using the theory and compare with the measured value!

4.1.4 Change the input voltage to about 0.1V (easiest is to press one -20dB button). (This is needed because with higher input voltage, the output becomes a triangle wave at high frequencies due to the Slew Rate limiting the output and this falsifies the measurement). Measure the upper frequency limit of the circuit. (Increase the frequency of the function generator until the output drops by -3dB, ie. to 70% of original.)

4.1.5 Setup 1kHz again on the function generator. Increase the input peak to peak voltage until the calculated value of the output signal ($A_v \cdot V_{\text{in}}$) should be greater than the power supply voltage. In this case the output signal will be distorted (limited, or cut). Draw the output waveform. Measure the maximum output voltages. Evaluate your findings.

4.2 Non-inverting amplifier

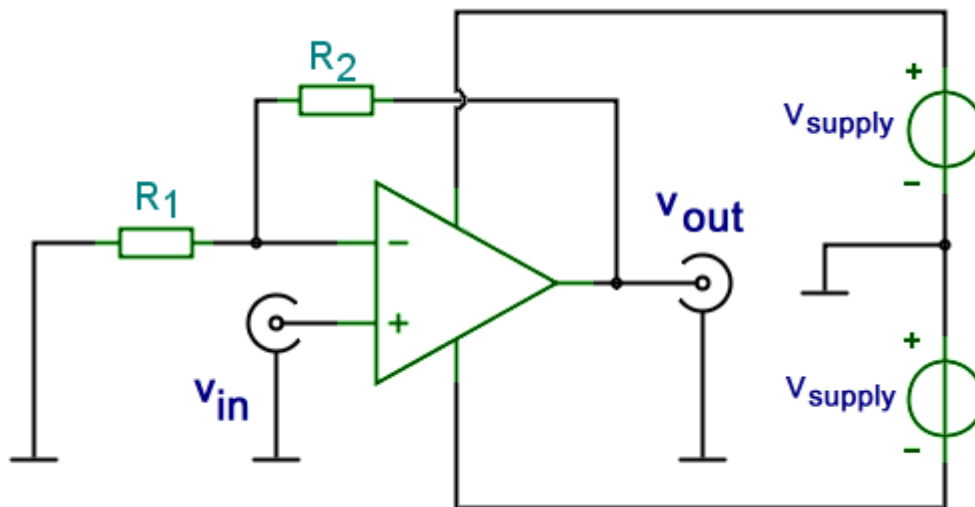

Figure 4.2 Non-inverting amplifier circuit

Modify the circuit from the previous exercise by connecting the previous input to ground and connecting the non-inverting input to the V_{in} as seen on figure 4.2. This means only exchanging two wires on the breadboard.

4.2.1 Setup 1kHz, 1Vpp (peak to peak) sine wave on the function generator. Draw and measure the input and output waveforms (peak to peak voltage, phase, voltage gain). Calculate the voltage gain using the theory and compare with the measured value! Is it inverting?

4.2.2 Measure the upper frequency limit of the circuit (similarly as previously).

4.3 Comparator with reference voltage

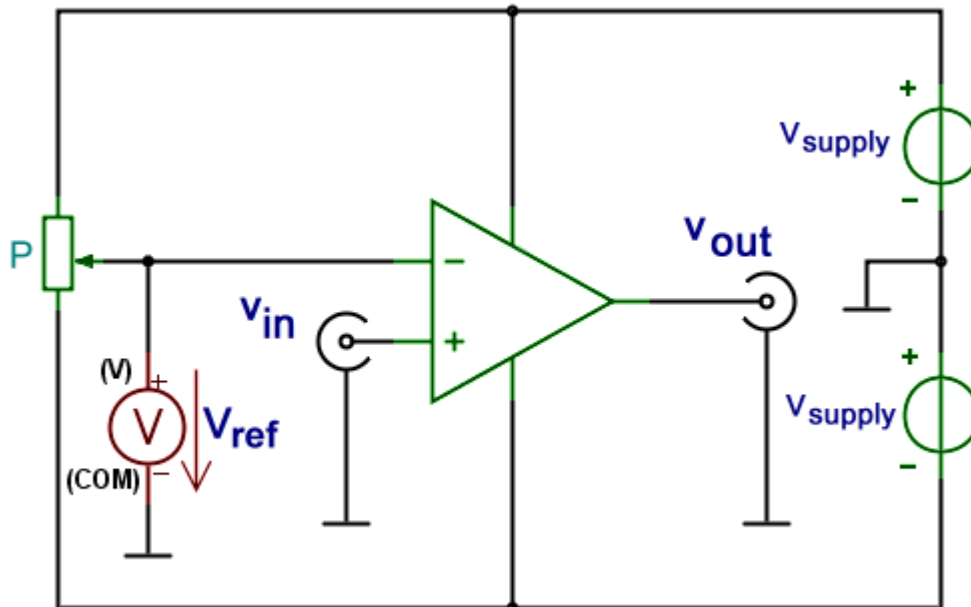

Figure 4.3 : Comparator circuit

Build the circuit of figure 4.3. This is a simple comparator. The reference voltage is supplied by potentiometer P. Connect this V_{ref} voltage to the multimeter and also to the oscilloscope (if it has a third channel). Setup all scope channels to zero y-position and same volts/div.

4.3.1 Setup 300Hz, 20Vpp (maximal) triangle wave on the function generator (this measurement needs lower frequencies because of the small SR value of the opamp). Measure V_{in} and V_{out} on the oscilloscope. Both channels should be DC coupled, their vertical zero level the same (use the GND setting to easily setup this level) and in the same V/div setting. Setup +5V reference voltage using the potmeter. Draw and analyse the output waveform.

4.3.2 Measure the $V_{ref} - d$ characteristics by stepping the value of V_{ref} in 1V steps through the whole range.

d is the duty cycle:

$$d = \frac{T_1}{T_1 + T_0} = \frac{T_1}{T}$$

$$T = T_1 + T_0$$

where T_1 is the duration of the high level of the output, T_0 is the duration of the low level, T is the period.

4.3.3 Measure the output slew rate (SR) (in V/ μ s) of the opamp. Setup the oscilloscope to magnify on the rising edge of the output signal, measure the $\Delta V / \Delta T$ of the edge. Compare with the catalogue value!

4.3.4 Swap the inputs of the opamp (connect V_{in} to pin 2 and V_{ref} to pin 3). Draw the waveforms and explain the difference.

4.4 Hysteresis comparator (Schmitt-trigger):

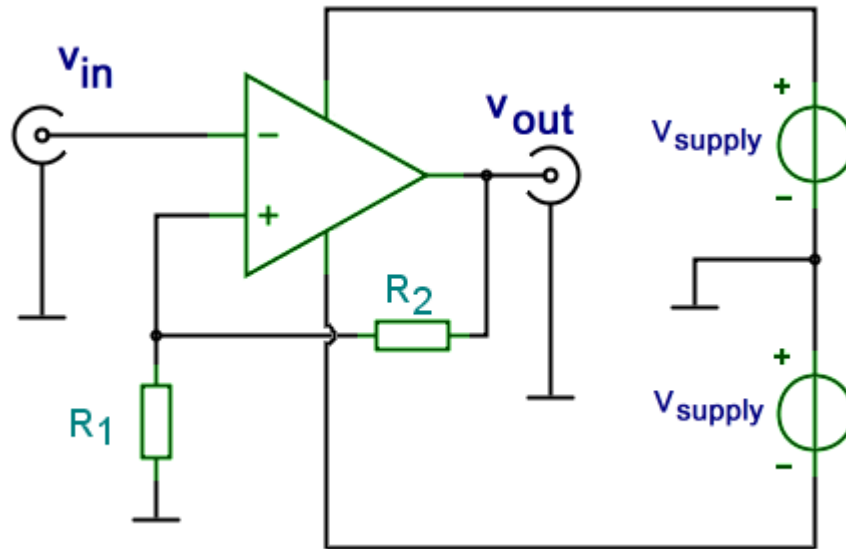

4.4: Hysteresis comparator with opamp

Build a hysteresis comparator circuit according to figure 4.4. In this circuit, V_{ref} is determined by the voltage divider made by R_1 and R_2 .

Parameters: $R_1=2.2k\Omega$; $R_2=10k\Omega$; $V_{supply}=10V$.

4.4.1 Using same input as in the previous exercise, measure and draw the input and output waveforms (again with same settings on both channels). Measure the two V_{ref} values (+ and -) (magnify into the waveforms!). (V_{ref} is measured at the non-inverting input).

4.4.2 The opamp's output is limited by the voltage supply. Because it is not ideal, the maximum output voltage is a little bit less than the supply. Measure the maximum output voltage (in both directions) and use these values to calculate the positive and negative V_{ref} values. Compare these with the measured values!

4.4.3 Measure the transfer characteristics of this circuit. Use the XY mode of the oscilloscope (in digital scope: either in Display menu or in Time menu YT»XY). It is suggested to use same V/div for both channels. (If you don't see the function properly, try changing the time/div setting.)

4.3 Test questions

1. Draw an inverting amplifier circuit and give its A_v formula.
2. Draw a non-inverting amplifier circuit and give its A_v formula.
3. Graph the frequency dependency (Bode-plot) of the opamp both in open-loop and feedback modes.
4. What is Slew Rate and what is its unit?
5. Define duty cycle.
6. What is output offset voltage?
7. Draw a hysteresis comparator and give the formula for the reference voltages.
8. Draw the output waveform for the hysteresis comparator if the input is triangle wave.
9. Draw the transfer function of the hysteresis comparator.
10. What do you know about the input and output resistances of an opamp?
11. What determines the maximum output voltage of an opamp?